



CONCAVE VACUUM CUPS WITH VULCANISED SUPPORT

These cups have been designed for gripping and handling cylindrical objects, such as pipes, bottles, round profiles, etc.

Their aluminium support is vulcanised onto the cup and it is provided with a central threaded hole to ease its fastening to the automation and with a side hole for insertion of an anti-rotation guide pin.

These cups can be provided in the three standard compounds: oil-resistant rubber A, natural para rubber N and silicone S.

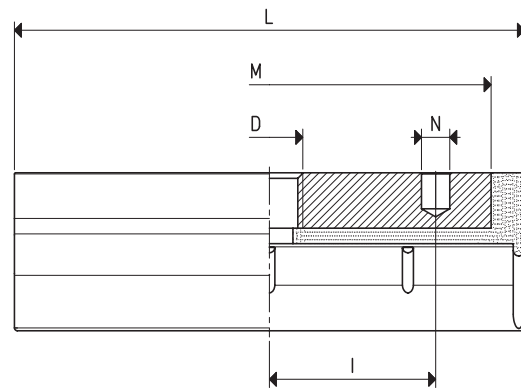
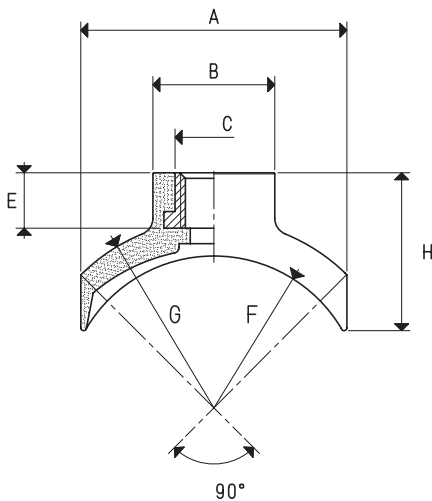

CONCAVE VACUUM CUPS WITH VULCANISED SUPPORT

Item	Force Kg	Volume cm ³	gripping Ø		A	B	C	D	E	F	G	H	I	L	M	N	Support material	Weight g
			min	max				Ø								Ø		
08 30 60 *	3.5	2.1	30	45	26	15	10	M8	8	16	19	20.0	20	60	50	4.1	aluminium	20.3
08 40 90 *	8.6	5.5	50	80	40	20	14	M12	10	23	28	25.0	30	92	80	5.1	aluminium	54.8
08 50 90 *	10.5	11.1	60	95	48	22	14	M12	10	28	34	28.5	30	92	80	5.1	aluminium	62.5

* Complete the code indicating the compound: A= oil-resistant rubber; N= natural para rubber; S= silicone

Note: The force of the vacuum cups indicated in the table represents 1/3 of the value of the theoretical force calculated at a level of vacuum of -75 KPa and a factor of safety 3.

Transformation ratio: N (newton) = Kg x 9.81 (force of gravity) inch = $\frac{\text{mm}}{25.4}$; pounds = $\frac{\text{g}}{453.6} = \frac{\text{Kg}}{0.4536}$