

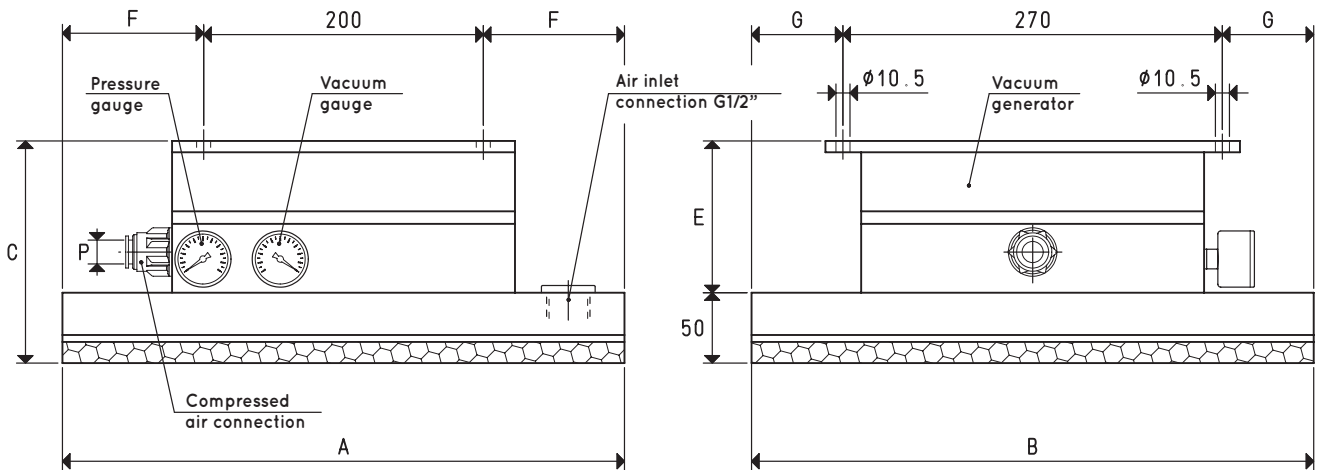

OCTOPUS VACUUM GRIPPING SYSTEM

3D drawings are available on vuototecnica.net

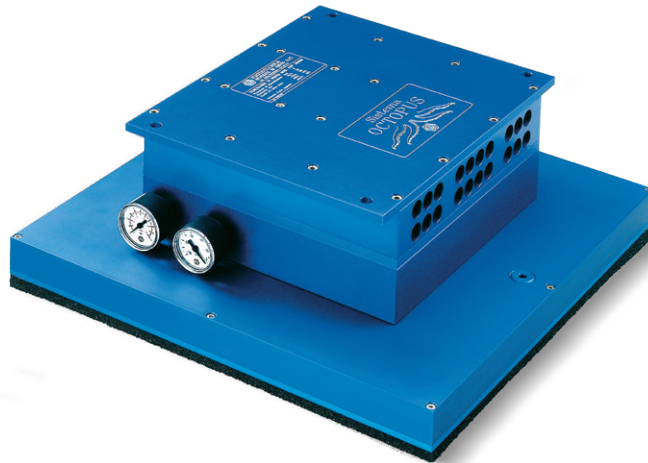

Item		SO 30 30 X	SO 30 40 X	SO 30 50 X	SO 40 40 X	SO 40 60 X
Suction plate	item	PX 30 30	PX 30 40	PX 30 50	PX 40 40	PX 40 60
Gripping force	Kg	63.6	84.8	106.0	113.1	169.6
Fitted for vacuum generator	item	N°1 PVP 150 MD PO	N°1 PVP 150 MD PO	N°1 PVP 300 MD PO	N°1 PVP 300 MD PO	N°1 PVP 300 MD PO
Maximum supply pressure	bar	6	6	6	6	6
Maximum level of vacuum	-KPa	90	90	90	90	90
Air consumption at 6 bar	NI/s	16.0	16.0	32.0	32.0	32.0
Intake air flow rate	m ³ /h	200.0	200.0	400.0	400.0	400.0
Temperature of use	°C	-20 / +80	-20 / +80	-20 / +80	-20 / +80	-20 / +80
Weight	Kg	11.5	12.5	15.0	17.0	19.0
A		300	400	500	400	400
B		300	300	300	400	600
C		138	138	158	158	158
E		88	88	108	108	108
F		50	100	150	100	100
G		15	15	15	65	165
P Connection for compressed air tube	Ø ext.	15	15	15	15	15

NOTE: The code SO ... X only identifies the OCTOPUS system body with relative suction plate PX.

The vacuum generator indicated in the table is not included with the OCTOPUS system and therefore must be ordered separately with its own code.

NOTE: All vacuum values indicated in the table are valid at the normal atmospheric pressure of 1013 mbar and obtained with a constant supply pressure.

Vacuum generator supply must be carried out with non-lubricated compressed air, 5 micron filtration, in accordance with standard ISO 8573-1 class 4.

Transformation ratio: N (newton) = Kg x 9.81 (force of gravity)

$$\text{inch} = \frac{\text{mm}}{25.4}; \text{pounds} = \frac{\text{g}}{453.6} = \frac{\text{Kg}}{0.4536}$$