



SINGLE-STAGE VACUUM GENERATORS PVP 7 SX / SXLP, PVP 14 SX / SXLP and PVP 18 SX / SXLP

Vacuum generators PVP ... SX/SXLP, operate making use of the previously described Venturi principle.

A special new generation silencer installed on them makes them very silent and, thanks to its shape, prevents them from becoming clogged, also allowing the suction of saturated fluids of water condensates or oils, mixed with fine or impalpable powders.

They are supplied as standard with a vacuum gauge for reading the level of vacuum. An additional connection on the body of the generator allows the installation of a vacuum switch for signalling the level of vacuum, or of a pneumatic solenoid valve for a quick restoration of the atmospheric pressure of use. They are fully made with anodised aluminium, with stainless steel ejectors and screws. These vacuum generators can be used for connecting one or more vacuum cups or equipment with flow rate requirements within the shown values and can operate in particularly dusty or damp environments. Available with suction rates between 8.3 and 18 m³/h and supply pressure 4-6 bar, for items SX and 1-3 bar for items SXLP.

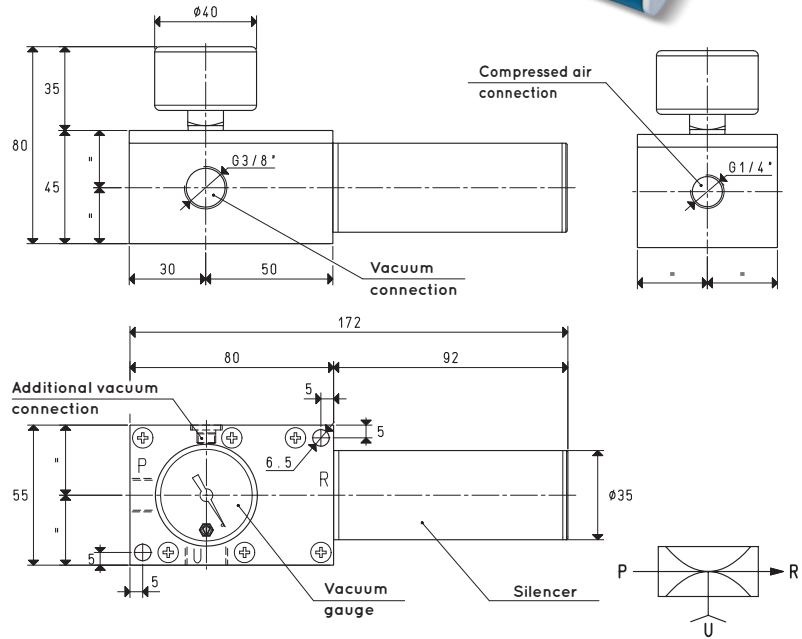

P=COMPRESSED AIR CONNECTION R=EXHAUST U=VACUUM CONNECTION

Item		PVP 7 SX			PVP 14 SX			PVP 18 SX			
Intake air flow rate	m ³ /h	9.5	9.5	9.3	14.0	14.0	13.5	18.5	18.5	18.0	
Maximum level of vacuum	-KPa	60	73	85	60	73	85	60	73	85	
Final pressure	mbar abs.	400	270	150	400	270	150	400	270	150	
Supply pressure	bar	4	5	6	4	5	6	4	5	6	
Optimal supply pressure	bar			6			6			6	
Air consumption	NI/s	2.3	2.7	3.2	3.2	4.0	4.8	4.3	5.4	6.4	
Operating temperature	°C		-20 / +100				-20 / +100			-20 / +100	
Noise level at optimal supply pressure	dB(A)			63			65			67	
Weight	g			470			480			490	
Item		PVP 7 SXLP			PVP 14 SXLP			PVP 18 SXLP			
Intake air flow rate	m ³ /h	8.3	9.6	8.8	11.7	14.0	13.6	15.0	18.3	17.5	
Maximum level of vacuum	-KPa	28	58	88	28	58	88	28	58	88	
Final pressure	mbar abs.	720	420	120	720	420	120	720	420	120	
Supply pressure	bar	1	2	3	1	2	3	1	2	3	
Optimal supply pressure	bar			3			3			3	
Air consumption	NI/s	2.2	3.4	4.5	3.4	5.2	6.9	4.5	6.6	8.6	
Operating temperature	°C		-20 / +100				-20 / +100			-20 / +100	
Noise level at optimal supply pressure	dB(A)			67			68			70	
Weight	g			470			480			490	
Spare parts		PVP 7 SX / SXLP			PVP 14 SX / SXLP			PVP 18 SX / SXLP			
Sealing kit	item	00 15 276			00 15 276			00 15 276			
Vacuum gauge	item	09 03 15			09 03 15			09 03 15			
Silencer	item	SSX 3/4" R			SSX 3/4" R			SSX 3/4" R			

Note: All vacuum values indicated in the table are valid at the normal atmospheric pressure of 1013 mbar and obtained with a constant supply pressure.

Vacuum generator supply must be carried out with non-lubricated compressed air, 5 micron filtration, in accordance with standard ISO 8573-1 class 4.

Transformation ratio: N (newton) = Kg x 9.81 (force of gravity)

inch = $\frac{\text{mm}}{25.4}$; pounds = $\frac{\text{g}}{453.6} = \frac{\text{Kg}}{0.4536}$

Adapters for GAS - NPT threading available on page 1.130



SINGLE-STAGE VACUUM GENERATORS PVP 7 SX / SXLP, PVP 14 SX / SXLP and PVP 18 SX / SXLP

Air flow rate (NI/s) at different level of vacuum (-KPa) at optimal supply pressure

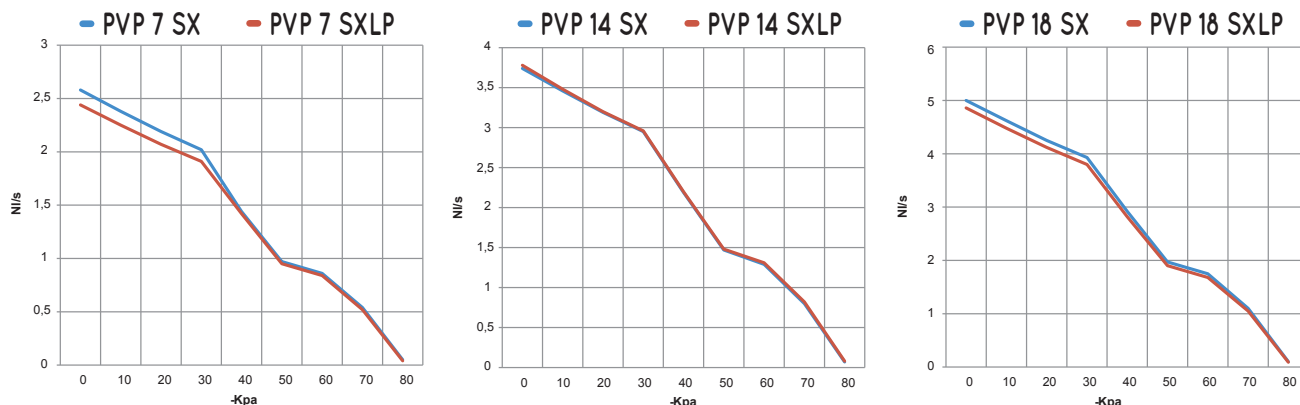

Generator item	Supp. press. bar	Air consumption NI/s	Air flow rate (NI/s) at different levels of vacuums (-KPa) at optimal supply pressure										Max vacuum -KPa
			0	10	20	30	40	50	60	70	80		
PVP 7 SX	6.0	3.2	2.58	2.38	2.19	2.02	1.44	0.97	0.86	0.54	0.05	85	
PVP 14 SX	6.0	4.8	3.75	3.46	3.19	2.95	2.19	1.47	1.29	0.80	0.07	85	
PVP 18 SX	6.0	6.4	5.00	4.62	4.25	3.93	2.92	1.97	1.75	1.10	0.10	85	
PVP 7 SXLP	3.0	4.5	2.44	2.25	2.07	1.91	1.42	0.95	0.84	0.52	0.04	88	
PVP 14 SXLP	3.0	6.9	3.77	3.48	3.20	2.96	2.20	1.48	1.31	0.82	0.07	88	
PVP 18 SXLP	3.0	8.6	4.86	4.48	4.12	3.80	2.82	1.90	1.68	1.05	0.09	88	

Evacuation rates (ms/l = s/m³) at different levels of vacuums (-KPa) at optimal supply pressure

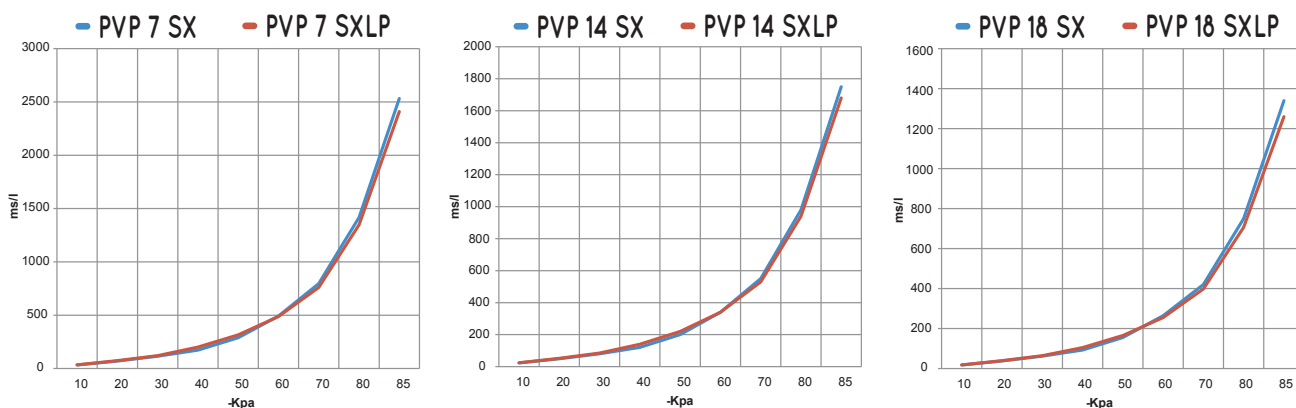

Generator item	Supp. press. bar	Air consumption NI/s	Evacuation rates (ms/l = s/m ³) at different levels of vacuums (-KPa) at optimal supply pressure								Max vacuum -KPa	
			10	20	30	40	50	60	70	80		85
PVP 7 SX	6.0	3.2	33	70	115	173	289	492	796	1418	2532	85
PVP 14 SX	6.0	4.8	23	49	80	120	200	340	550	980	1750	85
PVP 18 SX	6.0	6.4	18	38	62	93	155	264	420	750	1340	85
PVP 7 SXLP	3.0	4.5	34	74	121	200	315	487	760	1348	2410	88
PVP 14 SXLP	3.0	6.9	24	52	85	140	220	340	530	940	1680	88
PVP 18 SXLP	3.0	8.6	18	39	64	105	165	255	398	706	1260	88